

These operating instructions apply for:

PKL 125
PKL 135
PKL 150
PKL 170
PKL 200
PKL 220
PKL 240



Important Note:

Before use of the pneumatic impactors series PKL read this operating instruction carefully and store afterwards.

Netter GmbH does not assume liability for damage or injury resulting from technical modifications to the product, or failure to observe the instructions and warnings in this operating manual.

This documentation is subject to copyright. All rights e.g. for the translation, printing or reproduction of this operating manual, or parts thereof, are strictly reserved.

Contents





1	GENERAL NOTES	3
2	TECHNICAL DATA	3
3	DESIGN AND FUNCTION	6
4	SAFETY	8
5	TRANSPORT AND STORAGE	10
6	INSTALLATION	10
7	START-UP / OPERATION	17
8	SERVICE / MAINTENANCE	18
9	TROUBLESHOOTING	19
10	SPARE PARTS	19
11	APPENDIX	20
11.1	Accessories	20
11.2	Disposal	20
11.3	Enclosures	20

Scope of delivery



Check the packaging for possible signs of transport damage. In the event of damage to the packaging, check that the contents are complete and undamaged. If there is any damage, inform the shipping agent. Compare the scope of the delivery with the delivery note.

The following instruction and warning symbols are used in these operating instructions.

	Note on important procedures		Warning of a danger spot
	Important note on procedures to be especially observed		Environmentally friendly disposal
	Warning of loose sharing		

1 General Notes

Netter pneumatic impactors series PKL comply with the EC machine directive 98/37/EG. Standards DIN EN ISO 12100 part 1 and 2 have been particularly observed.

Interval impactors generate impacts against a base. Depending on the type and version, this may be an impact plate or the surface upon which the PKL is mounted.

General areas of application are the loosening of adhesive bulk materials from container walls (e.g. silos, funnels, filter outlets, pipelines and reactors) and emptying residues from weighing containers.

Also to prevent bridging and rat-holing, as long as the material remains capable of flowing.

Applications in food production and wet areas are possible, provided the corresponding company operating regulations are observed and the vibrator mounted is suitable for the application.

The impactors can also be used outdoors and in dusty environments, however not in or under water or other liquids.

The drive medium is clean (filtered) compressed air or nitrogen.

2 Technical Data

Drive medium

Clean (filter $\leq 5 \mu\text{m}$, class 3) compressed air or nitrogen

Operating pressure

The operating pressures must not be exceeded or fallen short of.

PKL 125/4: 3 bar to 5.2 bar
PKL 125/6: 5 bar to 6.9 bar
PKL 135/4: 3 bar to 5.2 bar
PKL 135/6: 4.5 bar to 6.9 bar
PKL 150/3: 2.5 bar to 3.9 bar
PKL 150/4: 3 bar to 5.1 bar
PKL 150/5: 4 bar to 5.7 bar
PKL 150/6: 5 bar to 6.9 bar
PKL 170/3: 3 bar to 4.7 bar
PKL 170/5: 4 bar to 6.5 bar
PKL 200/3: 3 bar to 4.6 bar
PKL 200/5: 4 bar to 6.4 bar
PKL 220/4: 3.5 bar to 5 bar
PKL 220/6: 5.5 bar to 7 bar
PKL 240/4: 3.5 bar to 5 bar
PKL 240/6: 5.5 bar to 7 bar
PKL 240/8: 7.0 bar to 9 bar

Impact frequency

Maximum 10 impacts in succession at an impact frequency of 15 impacts/min and 180 impacts/h.

This impact sequence must not be exceeded.

Lubrication

Interval impactors can be operated without oil provided the Netter GmbH application engineers have been consulted and the specified conditions are fulfilled.





Ambient temperature

-20°C to 60°C

HT Version: -20°C to 160°C

The permissible ambient temperatures must not be exceeded or fallen short of during operation.

*) Higher operating pressures and temperatures are only possible following consultation and written permission from Netter GmbH application engineers.

Type designation

The type designation of PKL impactors has the suffix /3, /4, /5, /6 or /8. These numbers are derived from the optimum operating pressure, i.e. the PKL 125/4 works most effectively at a pressure of 4 bar. The actual pressure set on the regulator must not exceed the optimum operating pressure by more than 1 bar (maximum pressure).

For ST versions at least the optimum operating pressure is to be set. For PKL 150/6 ST this is 5 bar.

Sound level

The sound level of a non-screened PKL, mounted on sheet metal exceeds 85 dB(A) (individual sound event).

Depending on the impact sequence, the permanent sound level will be lower.

The sound emitted by the unit can be dampened by a cover (upon request). This only makes sense if the impacted sheet metal is also dampened (e.g. by heat insulation material).

Instead of a steel impact plate, an elastomer plate may be inserted (upon request). This reduces the sound level by approx. 10 dB(A) (rubber hammer effect).

Example PKL 220

At pressures below 3 bar the /4 version is more powerful than the /6 version and is therefore suitable for networks with low air pressure.

A minimum pressure of 4 bar or 6 bar is strictly necessary for the version with ST kit, so that the reversal works correctly.

Type	Optimum operating pressure	Impact power*	Air consumption/impact at optimum pressure	Weight	Suitable for wall thicknesses
	[bar]	[kg]	[normal litres]	[kg]	[mm]
PKL 125/4	4.0	0.43	0.09	0.8	1 - 2
PKL 125/6	5.3	0.60	0.14	0.8	1 - 2
PKL 135/4	3.0	0.56	0.13	1.5	1 - 3
PKL 135/6	4.5	0.92	0.18	1.5	1 - 3
PKL 150/3	2.5	1.30	0.27	2.6	2 - 4
PKL 150/4	3.8	1.80	0.38	2.6	2 - 4
PKL 150/5	4.3	2.10	0.43	2.6	2 - 4
PKL 150/6	5.0	2.70	0.54	2.6	2 - 4
PKL 170/3	3.3	4.20	0.95	10.4	3 - 5
PKL 170/5	5.0	6.30	1.41	10.5	3 - 5
PKL 200/3	3.0	4.85	2.16	19.8	4 - 8
PKL 200/5	4.0	7.55	2.40	19.9	4 - 8
PKL 220/4	3.5	5.50	1.40	8.5	8 - 10
PKL 220/6	5.6	8.80	2.05	8.6	8 - 12
PKL 240/4	4.5	12.40	2.00	24.0	10 - 12
PKL 240/6	6.0	16.60	3.01	24.1	> 10
PKL 240/8	7.0	19.30	3.97	24.2	> 10

* The impact power corresponds to the effect of the given weight when dropped from a height of 1m.

PKL interval impactors can be used in dusty environments.

Interval impactors can be operated without oil provided the Netter GmbH application engineers have been consulted and the specified conditions are fulfilled.



Please note when planning:

All PKL types must be operated with a 3/2-way valve.

For automatic operation an optional control unit is required, e.g. Netter electronic timer AP 115.

Exception: PKL with ST kit (automatic control). In this case the control works automatically. The impact sequence can be regulated by using an additional throttle.

Dimensions

PKL 125

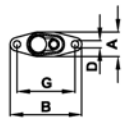

PKL 135

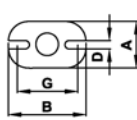

PKL 150

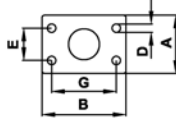

PKL 170, PKL 200

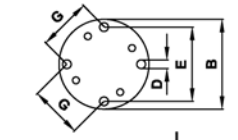

PKL 220

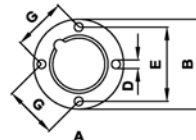

PKL 240

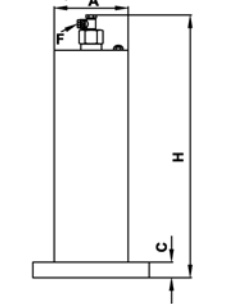
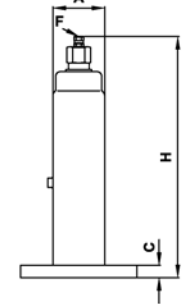
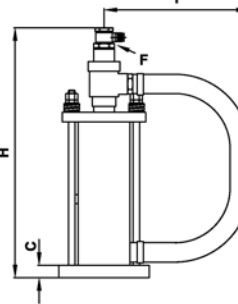
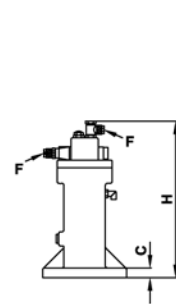
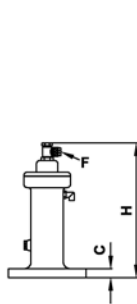
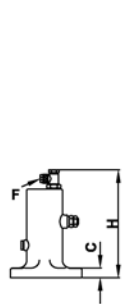
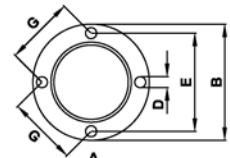

Type	A [mm]	B [mm]	C [mm]	Ø D [mm]	E [mm]	F	G [mm]	H [mm]	I [mm]
PKL 125	38	111	15	9.0	—	G 1/8, NW 6x1	90.0	167	—
PKL 135	72	120	14	13.0	—	G 1/8, NW 6x1	90.0	204	—
PKL 150	90	130	15	12.5	50	G 1/8, NW 6x1	100.0	240	—
PKL 170	—	Ø 140	19	13.5	Ø 115	G 1/8, NW 6x1	81.5	397	~230
PKL 200	—	Ø 180	24	17.0	Ø 152	G 1/8, NW 6x1	107,5	425	~230
PKL 220**	Ø 80	Ø 140/180	18/22	13.5/17.0	Ø 115/152	G 1/8, NW 6x1	81.5/107,5	380/384	—
PKL 240	Ø 114	Ø 180	27	17.0	Ø 152	G 1/8, NW 6x1	107.5	405	—

**) Mounting dimensions optionally as for PKL 170 or PKL 200

3 Design and Function

The pneumatic interval impactor is a pneumatic “hammer”.

Compressed air P flows beneath the piston C and pushes it against one or two springs B.

Upon exhaust, the air chamber below the piston is emptied all at once.

The piston (hammer) is shot against the impact plate E by the springs, and the plate transfers the blow (exception PKL 125, PKL 135 and PKL 150: here the piston strikes directly).

The air is evacuated via the quick air-exhaust valve A.

The unit is mounted via flange D by four fastening screws.

ST Kit

The ST kit connects the piston chamber to a 3/2-way valve.

The 3/2-way valve is automatically switched over when the piston uncovers the pilot bore.

With the ST kit the PKL strikes continuously as long as pressure is applied.

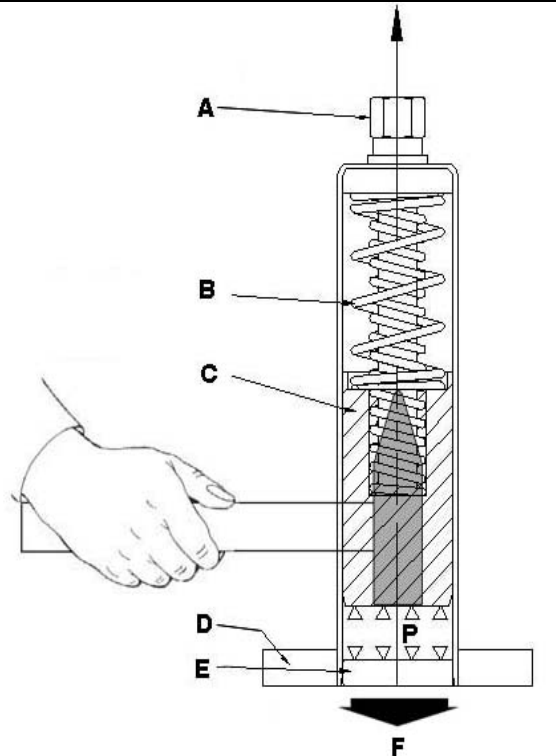

EE Kit

The EE kit reduces the sound level and creates a rubber hammer effect.

PKL 125 and PKL 135

Pneumatic interval impactors PKL 125 and PKL 135 only work after assembly, since the piston chamber is then sealed by an o-ring installed in the contact surface.

The working air supply must be connected to P.

The piston strikes directly against the mounting surface. The air channel is integrated in the housing.

An additional 3/2-way pneumatic valve is necessary if the control valve existing on site is more than 15 m away from the PKL.

The dampening set NBS 135 is compulsory for fastening the PKL 135 (not included in the supply of the PKL). See installation instructions for dampening set NBS 135.

EE Kit for PKL 125 and PKL 135

A spacer plate containing a replaceable elastomer and an o-ring is mounted between the base plate and the contact surface. See installation instructions for EE kit.

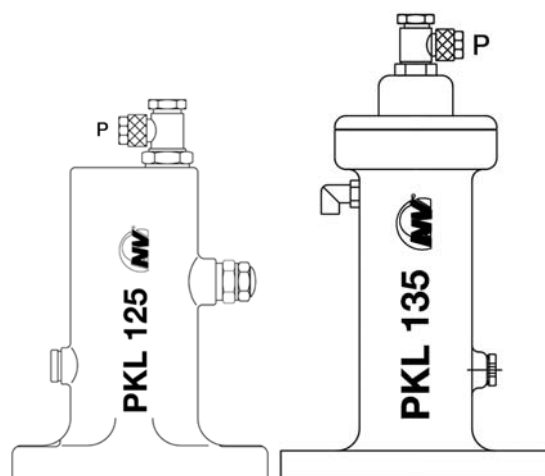

PKL 150

Pneumatic interval impactors PKL 150 only work after assembly, since the piston chamber is then sealed by an o-ring installed in the contact surface.

The working air supply must be connected to **P**.

The piston strikes directly against the mounting surface. The air channel is integrated in the housing.

A 3/2-way valve and a quick air-exhaust valve are integrated in the valve head of the PKL 150. The control valve existing on site can therefore be mounted at any distance from the PKL 150.

The pilot air supply must be connected laterally to **Z**. **S** is the exhaust outlet for the ventilation, to which a silencer is mounted.

ST Kit for PKL 150

The ST kit connects the pilot port to the piston chamber **Y-Z**. The impactor will then work as long as air is applied to **S** (**P** is then the exhaust).

In this case compressed air must only be supplied to **S**.

See installation instructions for ST kit.

Attention: When using automatic control ST, compressed air is connected to **S** ("normally open"). The silencer must be screwed onto port **P**.

EE Kit for PKL 150

A spacer plate containing a replaceable elastomer and an o-ring is mounted between the base plate and the contact surface. See installation instructions for EE kit.

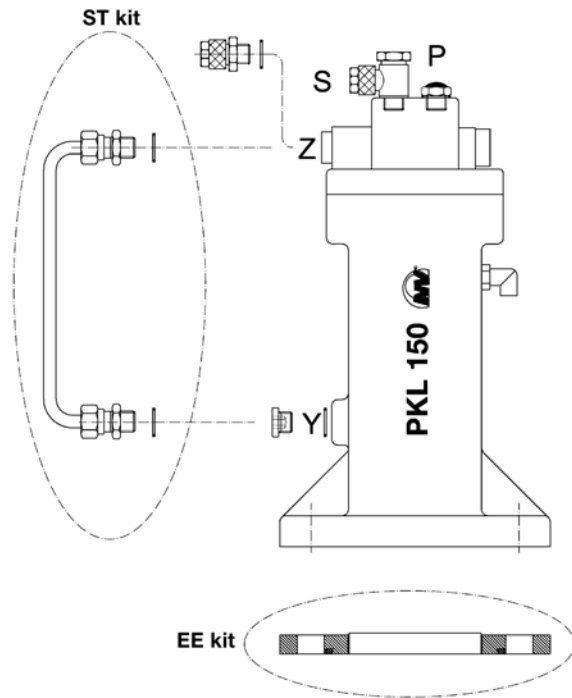

PKL 170 and PKL 200

These units are supplied either with a valve attachment **A** or an angular screw joint **B**.

The impactor must always be operated by a 3/2-way valve (available as an optional accessory), see circuit diagrams in chapter 6 "Installation".

The piston strikes against an impact plate.

Version **A** is required if the control valve existing on customer's site is more than 2 m away from the PKL.

If the control valve is less than 2m away from the PKL, version **B** can be used.

A shock absorber prevents damage to the pneumatic valve and allows rotation of the valve by 360°.

ST kits (see installation instructions for ST kit) and EE kits (see installation instructions for EE kit) are optionally available for the PKL 170 and PKL 200.

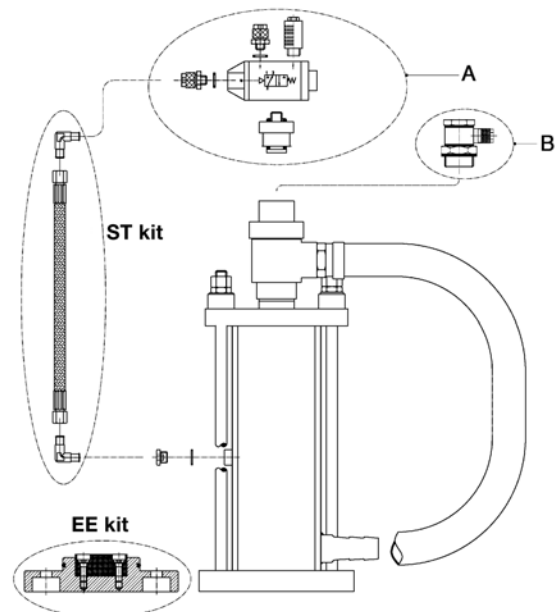

PKL 220 and PKL 240

The piston strikes against an impact plate **24**. The air channel is integrated in the housing. The compressed air escapes into the atmosphere via ventilation bores. The housing is shock-insulated (dampening ring), mounted in the replaceable flange plate and sealed by the impact plate **24** (steel or elastomer).

A 3/2-way pneumatic valve is required if the control valve on site is more than 15 m away from the PKL.

EE Kit for PKL 220:

An elastomer impact plate with an O-ring is installed in place of the steel impact plate **24**.

The PKL 220 and the PKL 240 must always be assembled with dampening ring **25** and damper plate **26**.

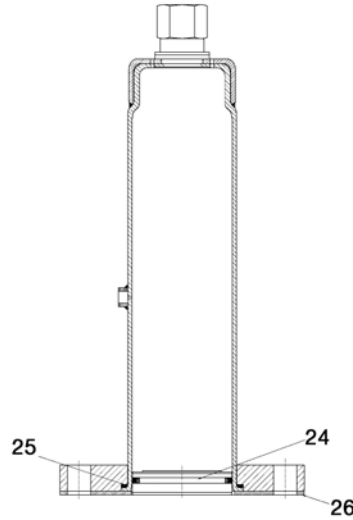

ST Kit for PKL 125, PKL 135 and PKL 220

Here a 3/2-way valve with air supply to **P** is required.

The ST kit connects the pilot port to the piston chamber.

The working air supply is connected to **P**, the pilot air supply laterally to **Z**. **S** is the air exhaust for the ventilation to which a silencer should be attached. The impactor will then work as long as compressed air is applied to **P**. See installation instructions for ST kit.

For circuit diagrams see chapter 6 "Installation".

The PKL 135 with ST kit is first attached to dampening set NBS 135, then the lower ST screws are mounted.

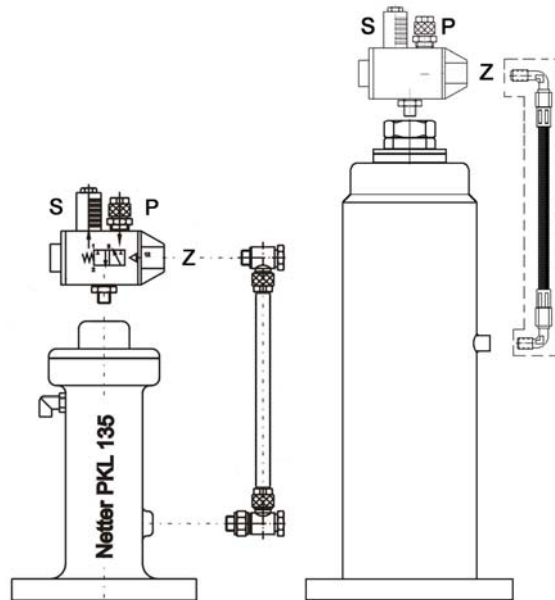

4 Safety



PKL impactors operate with compressed air. Ensure that the compressed air supply is shut off during installation.

Disconnect the air supply (open quick release coupling) before starting work on the vibrators or supply lines.

All hose connections must be tightly fastened before starting operation.

If a pressurized hose becomes loose it can cause injury.

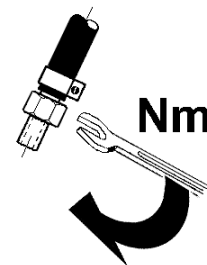

Pneumatic interval impactors PKL 125, PKL 135, PKL 150 and PKL 220 are open on the impact side. Ensure that the impact piston remains in the housing during installation !



Impactors, parts of the construction and air connectors may become loose, due to vibration. Falling parts can cause material damage or injury.

Screw retention devices and / or Loctite or similar are to be used. Screwed connections and air connectors should be checked after 1 hour of operation and then at regular intervals (generally once per month) and tightened, if necessary.

Netter fastening set NBS is recommended for the attachment of impactors PKL 125, PKL 150, PKL 170 and PKL 200.

Interval impactors PKL 135 must be installed with a dampening set; PKL 220 and PKL 240 with a damping ring and dampening plate.

In critical installation situations, it is possible to secure the vibrator with a clamp and steel rope.

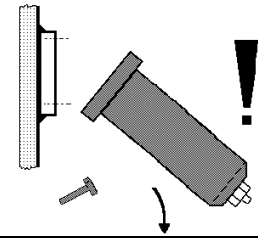

In the vicinity of the impactor, or structures connected to the impactor, the sound level can exceed 85 dB(A). When working in the noise area, ear defenders are required if the sound level exceeds 85 dB(A).



Drive medium

Clean (filter $\leq 5 \mu\text{m}$, class 3) compressed air or nitrogen

Operating pressure

The operating pressures must not be exceeded or fallen short of

- PKL 125/4: 3 bar to 5.2 bar
- PKL 125/6: 5 bar to 6.9 bar
- PKL 135/4: 3 bar to 5.2 bar
- PKL 135/6: 4.5 bar to 6.9 bar
- PKL 150/3: 2.5 bar to 3.9 bar
- PKL 150/4: 3 bar to 5.1 bar
- PKL 150/5: 4 bar to 5.7 bar
- PKL 150/6: 5 bar to 6.9 bar
- PKL 170/3: 3 bar to 4.7 bar
- PKL 170/5: 4 bar to 6.5 bar
- PKL 200/3: 3 bar to 4.6 bar
- PKL 200/5: 4 bar to 6.4 bar
- PKL 220/4: 3.5 bar to 5 bar
- PKL 220/6: 5.5 bar to 7 bar
- PKL 240/4: 3.5 bar to 5 bar
- PKL 240/6: 5.5 bar to 7 bar
- PKL 240/8: 7.0 bar to 9 bar

Lubrication

Interval impactors can be operated without oil provided the Netter GmbH application engineers have been consulted and the specified conditions are fulfilled.



Impact frequency

Maximum 10 impacts in succession at an impact frequency of 15 impacts/min and 180 impacts/h. This impact sequence must not be exceeded.

Ambient temperature

-20°C to 60°C
HT versions: -20°C to 160°C
The permissible ambient temperatures must not be exceeded or fallen short of during operation.

*) Higher operating pressures and temperatures are only possible following consultation and written permission from Netter GmbH application engineers.



Modifications

Modifications to the unit can alter the characteristics of the interval impactors or destroy the unit, and result in the rejection of all warranty claims.

5 Transport and Storage



Check the packaging for possible signs of transport damage. In the event of damage to the packaging, check that the contents are complete and undamaged. If there is any damage, inform the shipping agent.

The units are packed ready-to-install. The type label is attached to the impactor. Accessories and add-on parts are delivered unmounted, unless otherwise agreed. Special transport conditions are not stipulated. The units should be stored in a clean, dry environment. PKL pneumatic interval impactors must be oiled before going back into storage (pour machine oil into air inlet port and activate briefly).

PKL 125, PKL 135, PKL 150, PKL 220 and PKL 240 must be screwed or clamped to a plate before operation. The impact plate must be inserted. Use ear defenders.

The storage temperature should be between -40 and +60°C. This does not apply to the operating temperature; compare with chapter 4 SAFETY "Permissible Operating Conditions".

6 Installation



Ensure that the compressed air supply is shut off during installation or when working on the impactor and air supply lines.

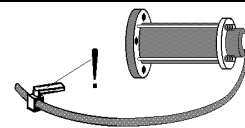

Pneumatic interval impactors PKL 125, PKL 135, PKL 150 and PKL 220 are open on the impact side. Ensure that the impact piston remains in the housing during installation !

Mounting the impactor



Series PKL 135 impactors must always be installed with damper kit NBS 135, according to the installation instructions! This damper kit is not included in the scope of delivery.
Series PKL 220 and PKL 240 impactors must always be installed with a dampening ring and dampening plate (included in scope of delivery)! Otherwise the housing may be damaged.



PKL impactors are screwed to level reinforcement sections or weld-on consoles ($\pm 0.3\text{mm}$ flatness). Suitable weld-on consoles are available from **NetterVibration** (see appendix). Please note that series PKL 125, PKL 135, PKL 150, PKL 220 and PKL 240 impactors are open at the bottom and can only work once they have been mounted to a plane surface.

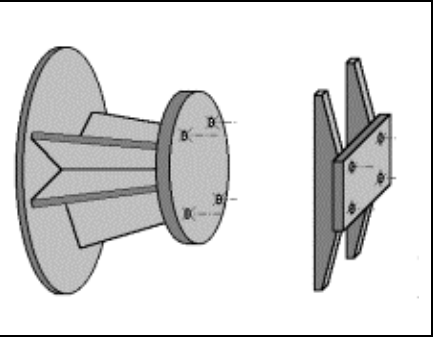

Weld-on plates must not be welded directly onto the panels of the construction, since they are too stiff. Use an intermediate layer of 1.5 times the sheet thickness (example A). Particularly in the type of attachment shown in A, the screws may break and are then difficult to replace, in contrast to example B. Fastening kits (screws, springs and appropriate washers) are available from **NetterVibration** upon request.

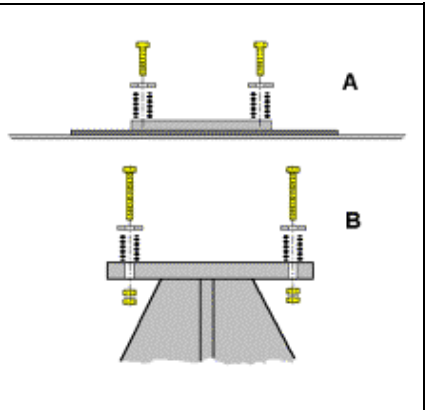

Please observe during installation: the permissible temperature range must not be exceeded during operation, see chapter 4, "Safety". Versions for other temperature ranges are available upon request.



Use lock nuts or locking fluid, e.g. Loctite 270, in order to prevent loosening. Also secure the compressed air supply lines with a suitable retention agent.

The tightening torques are to be taken from the following table. Higher tightening torques can lead to the fracturing of screws or tearing of threads. Incorrect attachment of screws can lead to detachment of the device. This can result in personal injury and damage to material!

Recommended average tightening torques for screws property class 8.8 on PKL housings (screws as delivered, with no additional lubrication)

Type	Thread / hole pattern [mm]	Tightening torque
PKL 125	M 10 / 90	51 Nm
PKL 135	with damper kit NBS 135 install acc. to installation instructions	
PKL 150	M 12 / 50 x 100	87 Nm
PKL 170	M 12 / 81.5 x 81.5	87 Nm
PKL 200	M 16 / 107.5 x 107.5	215 Nm
PKL 220 with flange type 170	M 12 / 81.5 x 81.5	87 Nm
PKL 220 with flange type 200	M 16 / 107.5 x 107.5	215 Nm
PKL 240 with flange type 200	M 16 / 107.5 x 107.5	215 Nm



When using fastening sets (NBS series) with screw or elastomer springs, the tightening torques are **lower**. Please observe the information and instructions supplied with these accessories.

Standard installation PKL

A cock valve **1** to shut off the main line and a service unit **2** are recommended for all installations. The service unit should consist of filter, regulator and, if possible, a mist lubricator.

In order to achieve optimum performance the PKL is generally recommended with an impactor-mounted 3/2-way pneumatic valve (integrated in the valve head for PKL 150).



Impact frequency

The permissible impact sequence must not be exceeded.

Standard installations for PKL 125, PKL 135, PKL 220 and PKL 240

A 3/2-way valve **3** must be used for the control.

A cock valve **1** to shut off the main line and a maintenance unit **2** are recommended for all installations. The maintenance unit should consist of filter, regulator and, if possible, a mist lubricator.

The impact occurs upon ventilation.

The impact sequence is determined by a Netter electronic timer AP 115 **4**. Electric or pneumatic controls are available.

Lubrication-free operation of interval impactors is possible, however, it is preferable to use an oil mister. The efficiency is increased when using oiled compressed air, since friction is reduced. The smallest reliably adjustable quantity of oil is sufficient.

The 3/2-way valve **3** can be installed at greater distances (up to 15 m) from the impactor.

Standard-Installation for
PKL 125, PKL 135,
PKL 220 and PKL 240

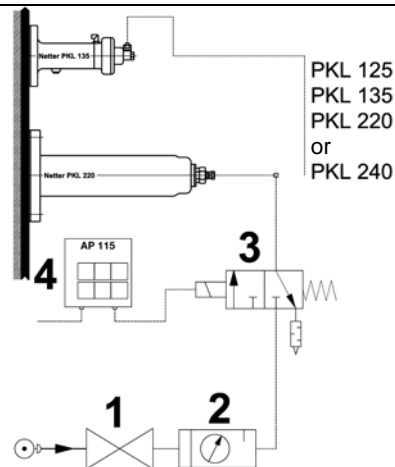

It is possible to operate several impactors in parallel with just one control and one valve.

Individual valves enable separate test operation, if they are fitted with manual controls for emergency operation.

The 3/2-way valve **3** can be installed at greater distances from the impactor (>15 m) if an additional 3/2-way pneumatic valve **9** is used.

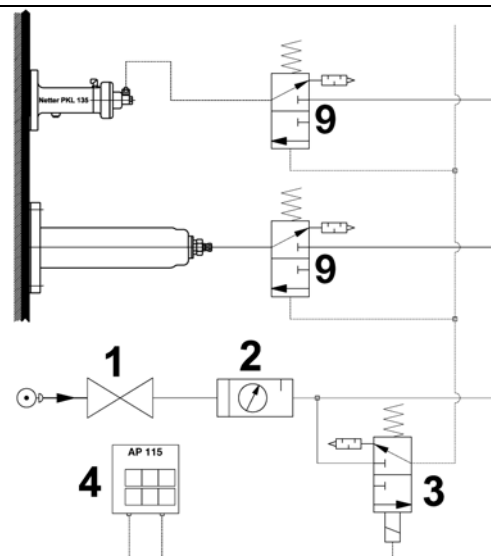

Installations for PKL 125, PKL 135 and PKL 220 with ST kit

With an ST kit the PKL continues to strike as long as pressure is applied. The PKL can then achieve an impact frequency of approx. one impact/second. This maximum impact sequence must be reduced to the max. permissible impact sequence (e.g. using a throttle valve **6** installed in the air supply line).

A PKL with ST-control **7** can be activated using a 2-, 3- or 4-way valve **3**, even if it is mounted at a greater distance (possible up to 50m). However, the ST-valve **9** must be mounted directly to or on top of the PKL.

If the valve for the ST-control is not mounted directly on the PKL, the connecting line from valve → PKL may only have a small volume (up to 0.5 m NW 4), otherwise the control piston in the unit will move too slowly and not reach the sealing final position. Upon request, the necessary ST kit for this type of connection can be supplied ready-to-install.

The PKL 135 with ST kit is first attached to dampening set NBS 135, then the lower ST screws are mounted.

In this installation PKL 135 ST and PKL 220 ST continue striking as long as the duty time set on the AP 115 **4** is running.

When the piston is pressed against the springs, a pilot bore is opened, whereby the valve **9** is ventilated via a by-pass **7** and the impact is triggered. Afterwards, the valve opens again and charges the PKL.

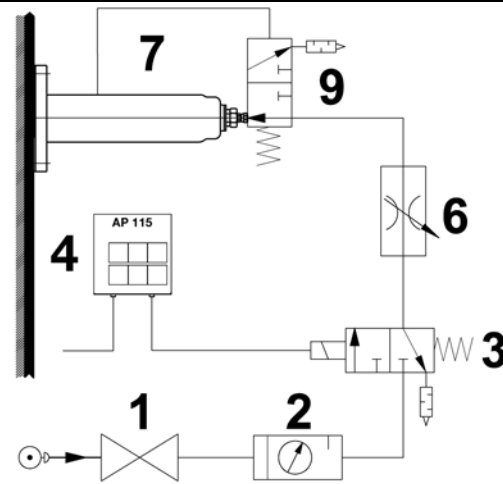

In this installation the PKL 125 ST is continuously striking as long as the duty time set on the AP 115 **4** is running.

The hose length ($2L$) between the throttle **6** and the 3/2-way valve **3** must at least have twice the length of the hose (L) between the 3/2-way valve **3** and the PKL 125.

$$2L = 2 \times L$$

For L we recommend a hose length of 1 m.

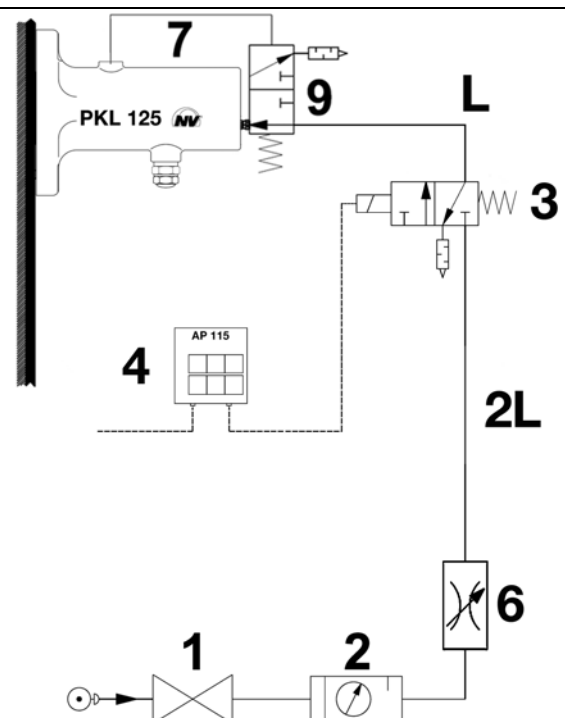



Impact frequency

The permissible impact sequence must not be exceeded.

Standard installation for PKL 150

The 3/2-way pneumatic valve is already integrated in the PKL 150. The control of several PKL operated in parallel is shown in the illustration.

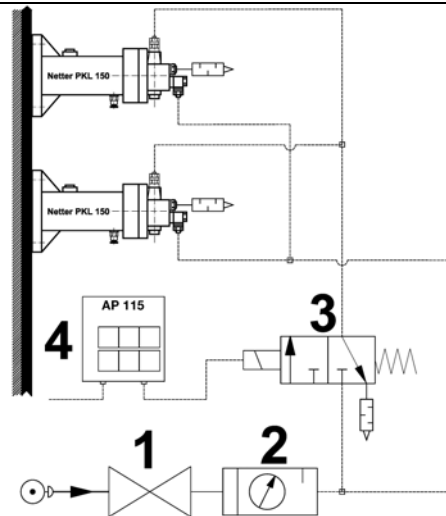

Installations for PKL 150 with ST kit

The **ST kit 7** connects the control port on the valve with a port on the housing. The piston reverses automatically, as long as compressed air of sufficient pressure is applied. The impact sequence can be adjusted using a throttle **6** between the 2/2-way or 3/2-way valve **5** and the impactor.

When controlled by a Netter electronic timer AP 115 **4**, the PKL will strike several times during the duty period.

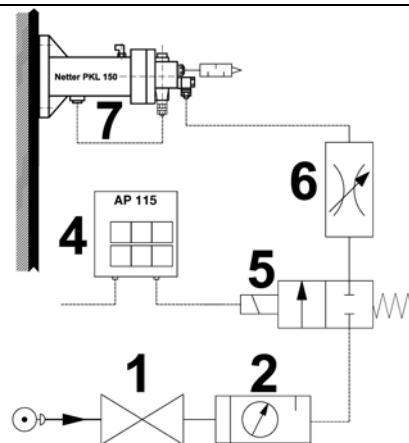

If the PKL 150 is fitted with an ST kit, it can be coupled to another function, without having to use a control or pulse generator. The adjoining illustration shows the coupling to an opening cylinder **8** on a weighing container. The impactor is not activated. Once the flap is opened, the impactor will strike at the frequency set by the throttle as long as the flap remains open.

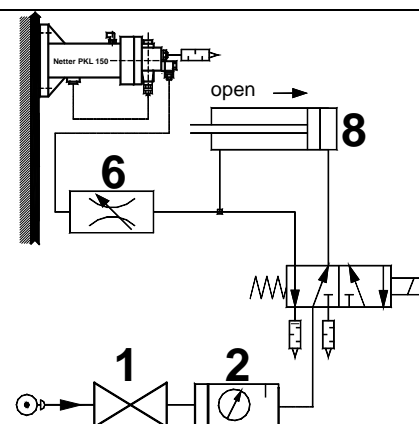

Standard installations for PKL 170 and PKL 200

The main air supply is constantly applied to the 3/2-way pneumatic valve **9**. The control line from the activation valve existing on customer's site **3** and the impactor can be very long (e.g. 50 m). In case of long supply and control lines the charge time of the impactor can take several seconds. If the compressed air lines are long (e.g. 50 m), a pause and duty time of at least 5 seconds should be set on the electronic timer AP 115 **4**. If shorter lines are used, these times can be reduced accordingly, e.g. to 2-3 seconds.

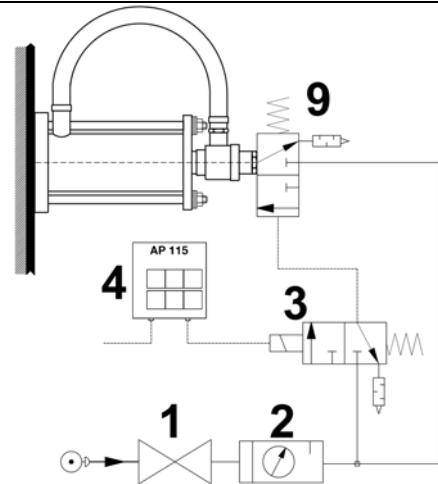

If these types are used without the built-on pneumatic valve, the control valve **3** must not be mounted more than 2 m max. away from the PKL and must have a nominal width of at least 6 mm for the exhaust, otherwise the efficiency will be reduced.

The 3/2-way solenoid valve **3** is activated via an AP 115 **4**, a SPS control or a similar device. The duty time (charging) should be at least 1-2 seconds for a distance of 2 m between the valve and the PKL. The impact occurs at the end of the charge time when the activation valve is ventilated.

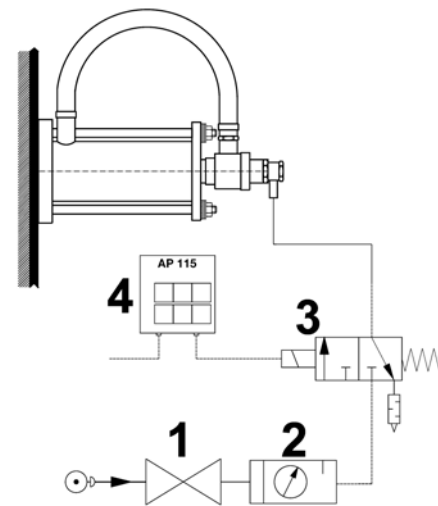

Installation for PKL 170 and PKL 200 with ST kit

In this installation the PKL continues striking as long as the duty time set on the AP 115 **4** is running.

The piston reverses automatically, as long as compressed air of sufficient pressure is applied. The impact sequence can be adjusted using a throttle **6**.

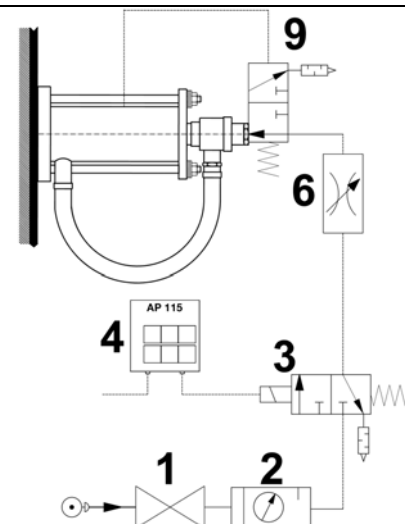

Recommended cross-sections for valves and hoses

PKL 125:

Control lines, control valves: NW 6 × 1
Main air supply: NW 6 × 1

PKL 135:

Control lines, control valves: NW 6 × 1
Main air supply: NW 6 × 1

PKL 150:

Control lines, control valves: NW 6 × 1
Main air supply: NW 6 × 1

PKL 170 and PKL 200:

Control lines, control valves: NW 6 × 1
Main air supply: NW 9 × 1,5

PKL 220 und PKL 240:

Control lines, control valves: NW 6 × 1
Main air supply: NW 9 × 1,5



- 1) For control valve with direct activation (PKL 170 and PKL 200 without impactor-mounted pneumatic valve): consider at least NW 6.
- 2) For simultaneous activation of several PKL: consider larger cross-sections for the main line up to distribution to the individual units.



Use NW 6 (max 15 m) for connection of the control valve to PKL 125, PKL 135, PKL 220 and PKL 240.
For the activation of several PKL 125, PKL 135, PKL 220 or PKL 240 the total length must not exceed 50 m (see illustrations on page 14).

Checklist for installation:

- 1) Consider expected operational temperature.
- 2) Install PKL 135 with dampening set.
- 3) Install PKL 220 and PKL 240 with dampening ring and dampening plate.
- 4) Secure fastening screws.
- 5) Install the service unit (filter, mist lubricator, regulator, as required), valve and supply line.
- 6) Are fastening screws secured? Check!
Are compressed air supply lines glued in? Check!
- 7) Has the information on hose length and nominal width been observed?
Is the unit secured from falling down?
- 8)

7 Start-Up / Operation



Lubricated compressed air is recommended for PKL impactors:

Fill mist lubricator with acid and resin free pneumatic oil, ISO viscosity class according to DIN 51519, VG 5 to VG 15.

Recommendation: Klüber "AIRPRESS 15" for temperatures up to 60°C.

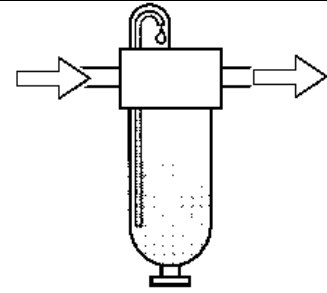

When selecting the lubricator, bear in mind that the air consumption of the PKL is very low. The selection of the lubricator is dependent on the number of impactors to be operated at the same time.

Units with 1/8" and 1/4" connectors are recommended. Larger units may not respond.

Set to the lowest number of drops.



ATTENTION:

Adjust the number of drops with the unit running.

Only after the mist lubricator has been adjusted and is functioning correctly the device is ready for operation.

Regulation of Impact Strength:

The impact strength can be reduced by lowering the pressure (exception ST kit). Throttling the air supply (via a throttle, cut-off valve, etc.) will not reduce the impact strength, but will delay the charge time.

Regulation of Impact Frequency:

The impact frequency must be regulated using an external control with a 3/2-way valve and a Netter electronic timer AP 115.

Exceptions: PKL with ST kit.



Impact frequency

Max. 10 impacts in succession at an impact frequency of 15 impacts/min and 180 impacts/h.

This impact sequence must not be exceeded.

Checklist for start-up:



- 1) Adjust mist lubricator, if available.
- 2) Check hose connections before opening the compressed air supply.
- 3) If required, set the desired impact strength on the pressure regulator (does not apply if ST kit is installed).
- 4) If ST kit is installed the frequency can be regulated using a throttle. Do not set faster than necessary (service life, noise pollution).
- 5) The attachment screws and compressed air lines should be checked after 1 hour of operation and tightened, if necessary. After this, the attachment screws and compressed air lines should be checked at regular intervals (generally once per month) and tightened, if necessary.

8 Service / Maintenance



Please observe the safety regulations in chapter 4 when servicing the device.



Before starting inspection or service work, shut off the compressed air supply and protect it against unintentional activation!

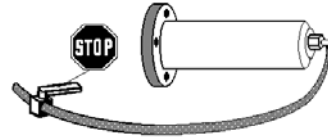

The drive medium must be clean (filter $\leq 5 \mu\text{m}$, class 3).
Unfiltered compressed air leads to high wear, blocked silencers or complete break-down of the impactor. The maintenance intervals are reduced.

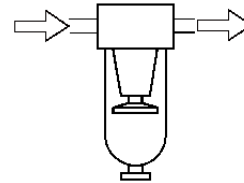

$\leq 5 \mu\text{m}$
Filter recommended



The following maintenance work must be regularly performed (preferably once per month) by an authorized specialist:

- a) Inspection of screw connections
- b) Inspection of air supply lines, including upstream maintenance unit
- c) Inspection of silencers
- d) With an upstream mist lubricator, ensure that the unit is working as required (contents decreasing? no. of drops/h?). Refill oil.
- e) Empty filter if necessary, clean filter insert (wash out), replace filter insert.
- f) Check the dampening plate of PKL 220 and PKL 240.
- g) Check the total number of impacts.



The maintenance intervals largely depend on the operating times and the cleanness of the drive medium. Especially in units driven by oil-free and / or dried compressed air, increased friction can create deposits which will slow down the function.

If this is noticed (drop in power or even standstill), the impactors should be cleaned and the sealing and guide rings replaced, if necessary. The maintenance intervals are reduced.

Cleaning the impactor:

When cleaning the impactor, it is necessary to remove and clean the piston. In case of wear, the guide rings and piston seals must be replaced. A special tool is necessary (available upon request) to insert the piston. Alternatively, maintenance, repair and comprehensive servicing can be carried out by **NetterVibration**.



After a maximum of 500.000 impacts a comprehensive service should be carried out during which all seals and guide rings should be replaced.

9 Troubleshooting

Fault	Possible causes	Fault finding	Remedy
No function	Silencer soiled	Silencer on PKL 150 and 3/2-way valve	Clean silencer on valve and unit.
	Impact plate missing Seal missing	Leakage at impact plate	Insert impact plate with seal - PKL 220 and PKL 240.
	Malfunction of valve and control	Check impactor without valve and control. For this purpose clamp impactor with dampening plate on to a plate. Charge with a delivery hose slid over the fitting. Hold the hose securely tight and pull it off. The impactor must strike.	Check 3/2-way valve and control, replace if necessary
	Air supply	Assembly with ST-kit: Sufficient pressure? Check impactor function manually (see above).	Adjust operating pressure
	Unit or valve soiled	Check control valve for dirt	Clean and oil piston, clean control valve and check function.
No function with leakage from top	Sealing material	Lock nut leaking PKL 220 and PKL 240.	Seal the nut with removable sealing agent, e.g. Loctite 577.
	Wear	Check seals on knocking and control pistons PKL 125, PKL 135, PKL 220 und PKL 240.	Replace seals on knocking piston and control piston.
	General wear	Housing and valve tube worn?	Replace affected parts and seals.
No function with ST kit, leakage from top.	ST valve too far away, control piston moves too slowly and does not close.	Function test without ST valve: for this purpose screw a nozzle into the top, screw in a blind plug and check the function PKL 135, PKL 220.	Respect max. hose length and NW.
Weak impact	Air supply	Check pressure	Adjust the pressure
	Contamination		Clean parts
	Wear, leakage	Test see above	Replace the seals

10 Spare Parts

When ordering parts, please supply the following details:

1. Required quantity
2. Description and position of the spare part
3. Type of unit

11 Appendix

11.1 Accessories

The following accessories are available for the interval impactor PKL (upon request):

Description	Remarks
ST kit	When using this type of control, the pauses between the individual impactor sequences must be long enough (see chapter 6).
Hose material and fittings	For compressed air supply (working air, pilot air), in various qualities and dimensions.
Way valves	Electrical, pneumatic, manual
Throttle valves	For cycle control on PKL with ST kit
Maintenance units	Filter, regulator with pressure gauge, mist lubricator
Netter electric timers	Electrical (also for special voltages) or pneumatic controls.
Weld-on consoles	For round and rectangular containers, also for use on insulated containers, funnels etc.
Vacuum fixing devices, quick clamping devices	For quick relocation on containers etc.
Noise reduction	Hoods, covers, EE kit.
Safety suspension	Clamp with steel rope and snap hooks (see chapter 4). Flanges with different dimensions available at extra cost, high-temperature versions and further information on request.
Special versions:	

11.2 Disposal

The parts are to be correctly disposed of, depending on the material.

Material specifications:

	PKL 125	PKL 135	PKL 150	PKL 170 and 200	PKL 220	PKL 240
Stainless steel					housing, cover disc, plug screw, lock nut and counter nut	cover disc, lock nut and counter nut
Steel	piston, springs	piston, springs	piston, springs	all parts	replaceable flange plate, impact piston, impact plate, valve pipe, springs, piston screws	housing, cover, flange, impact plate, valve pipe, impact piston, springs, ring nut, piston screws
Aluminium	housing, pilot piston	housing, pilot piston	housing		pilot piston	pilot piston
PTFE, PU, VITON, UBR	Spring guide, ring stop, seals	cover, seals	lid, seals, membranes	seals, membranes	seals, dampening rings, dampening plates, impactor plateEE	seals, dampening rings, dampening plates,
Valves: Brass, nickel-plated						



All units can be disposed of through Netter GmbH.
The applicable disposal prices are available upon request.

11.3 Enclosures

Enclosure(s):

Declaration of conformity
List of spare parts



**Additional information available upon request:
Leaflet No. 27 (PKL), and others.**