

These operating instructions apply to:

NTK 8 AL  
NTK 15 x  
NTK 16  
NTK 18 AL  
NTK 25 AL  
NTK 25

NTK 40 AL  
NTK 40  
NTK 55 AL  
NTK 55  
NTK 85  
NTK 110



**Important note:**

Before use of the pneumatic linear vibrators series NTK read this operating instruction carefully and store afterwards.

Netter GmbH does not assume liability for damage to property and persons if the product has been technically modified or if the notes and regulations of these operating instructions have not been observed.

This documentation is copyrighted. All rights, e.g. for translation into other languages, reprinting and copying of these operating instructions or parts hereof remain strictly reserved.

## Table of Contents

<b>1</b>	<b>GENERAL NOTES</b>	<b>3</b>
<b>2</b>	<b>TECHNICAL DATA</b>	<b>4</b>
<b>3</b>	<b>DESIGN AND FUNCTION</b>	<b>7</b>
<b>4</b>	<b>SAFETY</b>	<b>8</b>
<b>5</b>	<b>TRANSPORT AND STORAGE</b>	<b>9</b>
<b>6</b>	<b>INSTALLATION</b>	<b>10</b>
<b>7</b>	<b>START-UP / OPERATION</b>	<b>13</b>
<b>8</b>	<b>SERVICE / MAINTENANCE</b>	<b>14</b>
<b>9</b>	<b>TROUBLESHOOTING</b>	<b>15</b>
<b>10</b>	<b>SPARE PARTS</b>	<b>15</b>
<b>11</b>	<b>APPENDIX</b>	<b>16</b>
11.1	Accessories	16
11.2	Disposal	16
11.3	Enclosures	16

### Scope of delivery:



Check the packaging for possible signs of transport damage. In the event of damage to the packaging, check that the contents are complete and undamaged. If there is any damage, inform the shipping agent. Compare the scope of the delivery with the delivery note.

## 1 General notes

Pneumatic linear vibrators of series NTK comply with the EC-machine regulation 98/37/EG. In particular, standards DIN EN ISO 12100 part 1 and 2 have been observed.

The vibrators generate directed linear vibrations or shaking movements.

General areas of application are: Loosening, conveying, compacting, separating of bulk materials and reduction of friction.

NTK - vibrators are used to empty bunkers, to drive conveyor troughs, screens and vibrating tables.





Applications in the food industry as well as in wet environments are also possible, when complying with the operating instructions of the operating company.

The drive medium is compressed air or nitrogen.

In addition, the frequency can be infinitely controlled by means of pressure regulators or throttles in the supply line and the amplitude by installation of a throttle in the exhaust line.

Weights can be attached to piston or housing to increase working moment and thereby the amplitude. This reduces the frequency at the same time.

In these operating instructions the following information and danger symbols are used.

	Notes on important processes		Warning of a danger source
	Important note on processes to be especially observed		Environmental waste disposal

## 2 Technical data



### Drive medium:

Clean (filter  $\leq 5 \mu\text{m}$ ) compressed air or nitrogen  
**Unfiltered air will cause damage to the vibrators.**

### Operating pressure:

2 bar to 6 bar\*  
 Operating pressures must not be exceeded or fallen short of.

### Temperature:

NTK 15 x with plastic housing:  $5^{\circ}\text{C}$  to  $100^{\circ}\text{C}^*$   
 NTK with aluminium housing (black):  $5^{\circ}\text{C}$  to  $60^{\circ}\text{C}^*$   
 NTK with steel housing (orange):  $-10^{\circ}\text{C}$  to  $150^{\circ}\text{C}^*$   
 Operating temperatures must not be exceeded or fall short of.

### Lubrication:

After receiving a written confirmation from application engineers of **NetterVibration** vibrators NTK 8 AL, NTK 15 x, NTK 18 AL, NTK 25 AL, NTK 40 AL und NTK 55 AL may be operated without oil. (Exception: With dried air and under extreme ambient conditions).

When using lubricated compressed air, the units with the designation „AL“ reach a considerably longer service life than comparable units made of steel or cast iron ( housings painted orange or made of stainless steel). However, the permitted operating temperature of AL-vibrators is lower.

**All other vibrators must strictly be operated with lubricated compressed air or lubricated nitrogen.**

When using dry air, the installation of a lubricator is mandatory.

Special versions (stainless steel, bronze) on request.

\*) Higher operating pressures and temperatures are only permitted after consultation and written confirmation by application engineers of Netter GmbH.

The housing is bolted to the mass to be vibrated.

The piston oscillates freely.

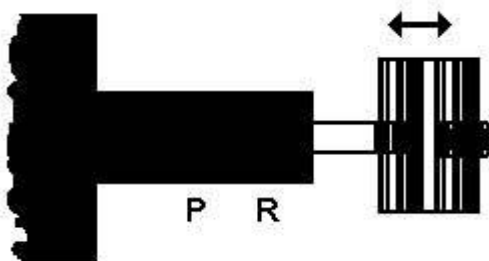

Housing on mass to be vibrated  
 Piston with weight oscillating

Alternatively, the piston may also be bolted on the mass to be vibrated. In this case the housing oscillates.

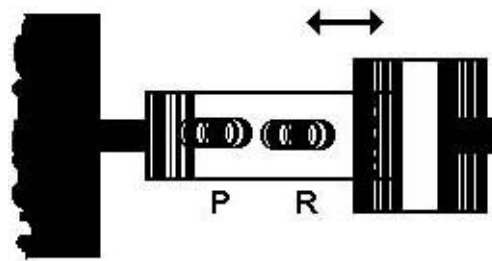

Piston on mass to be vibrated  
 Housing with weight oscillating

The working moment depends on the weight of the freely oscillating part and the amplitude. Amplitude and working moment change if the weight of the freely oscillating part is modified (e.g. by installation of an additional vibration weight SM on piston or housing). This means that the working moment can be pre-selected by choosing the freely oscillating part with the corresponding weight.

The following table shows the technical data for the freely oscillating piston (**SW 1**) as well as for the freely vibrating housing (**SW 2**), the lower value is for 2 bars, the higher value is for 6 bars.

Intermediate values can be reached by changing the pressure. On some types the weight differences of piston and housing are only very small. In such cases the data for the freely oscillating piston (**SW 1**) and the freely oscillating piston with a common vibrating mass SM (**SW 3**) are indicated. The designation of the vibrating mass SM is given in brackets (P+ SM 8-2 which means piston plus vibrating mass SM 8-2).

Vibrating weights are available as accessories, see chapter 11.1.

Type		Weight [kg]	Working moment [cmkg]	Nominal frequency [min <sup>-1</sup> ]	Centrifugal force [N]	Air consumption [l/min]
<b>NTK 8 AL*</b>	SW 1	0,030	0,05 - 0,06	2.440 - 3.657	15 - 44	7 - 32
	(K+SM 8-2) SW 3	0,088	0,15 - 0,21	1.380 - 2.080	15 - 50	6 - 25
<b>NTK 15 x*</b>	SW 1	0,135	0,29 - 0,29	1.745 - 2.544	49 - 104	17 - 72
	(K+SM 16-2) SW 3	0,675	1,69 - 1,69	758 - 1.152	53 - 123	14 - 54
<b>NTK 16</b>	SW 1	0,15	0,27 - 0,34	1.680 - 2.400	42 - 106	14 - 58
	SW 2	1,33	4,90 - 4,50	600 - 923	96 - 210	8 - 39
<b>NTK 18 AL*</b>	SW 1	0,21	0,29 - 0,36	1.600 - 2.350	41 - 109	19 - 68
	(K+SM 16-1) SW 3	0,53	1,18 - 1,41	972 - 1.572	61 - 191	13 - 58
<b>NTK 25 AL*</b>	SW 1	0,420	1,18 - 1,24	1.289 - 1.986	107 - 269	34 - 149
	(K+SM 25-3) SW 3	1,655	6,88 - 6,55	686 - 1.080	177 - 419	22 - 115
<b>NTK 25</b>	SW 1	0,47	1,12 - 1,32	1.440 - 2.270	127 - 374	38 - 156
	SW 2	2,60	9,10 - 9,82	690 - 1.067	237 - 612	24 - 102
<b>NTK 40 AL*</b>	SW 1	1,240	2,88 - 2,16	1.231 - 2.094	239 - 519	54 - 220
	(K+SM 25-3) SW 3	2,475	6,72 - 7,44	900 - 1.389	298 - 787	36 - 210
<b>NTK 40</b>	SW 1	1,27	3,57 - 2,46	1.200 - 1.930	282 - 503	49 - 228
	SW 2	4,20	19,48 - 16,36	600 - 1.108	385 - 1.100	34 - 161
<b>NTK 55 AL*</b>	SW 1	2,10	3,62 - 2,66	1.500 - 2.400	447 - 839	98 - 398
	(K+SM 85-1) SW 3	3,43	7,25 - 6,28	1.113 - 1.768	492 - 1.077	83 - 384
<b>NTK 55 (HF)</b>	SW 1	2,10	2,49 - 2,49	1.760 - 2.836	423 - 1.099	65 - 295
	(NF) SW 2	5,90	14,4 - 13,47	884 - 1.467	617 - 1.588	64 - 330
<b>NTK 85 (HF)</b>	SW 1	5,20	3,01 - 3,88	2.520 - 3.800	1.047 - 3.075	118 - 431
	(NF) SW 2	12,10	13,59 - 13,11	1.200 - 1.838	1.073 - 2.428	148 - 532
<b>NTK 110</b>	SW 1	8,00	6,03 - 7,87	2.133 - 3.040	1.505 - 3.986	210 - 652
	SW 2	16,60	13,48 - 15,93	1.447 - 2.133	1.548 - 3.974	207 - 634

These technical data are reference values and may vary in dependence on the application, further data on request.

\*) oil free operation is only permitted after consultation and written confirmation by application engineers of Netter GmbH

#### Noise level:

Depending on the type (with silencer) and at an air pressure of 6 bar the noise level is about 78-80 dB(A). It decreases if the air pressure is reduced.

#### Time of operation:

Long operating periods change the performance data due to wear.

## Dimensions [mm]

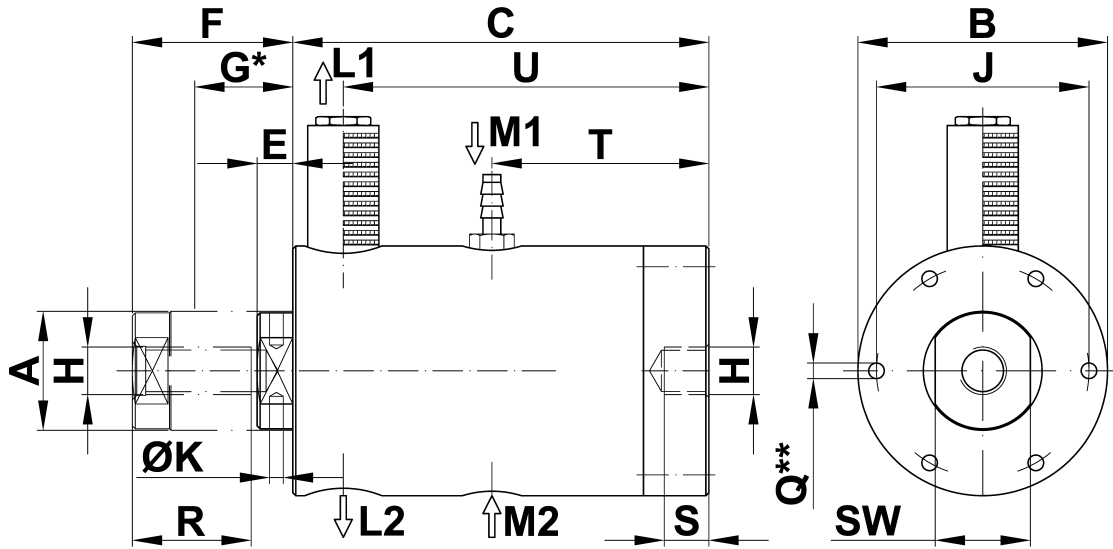

Type	A	B	C	E	F	G*	H	J	K	L	M	Q**	R	S	T	U	SW
NTK 15 x	15	50	114	9	38	23,5	M 10	—	—	G 1/8	G 1/8	—	20	10	55	99	13
NTK 16	16	49	111	5	38	21,5	M 10	—	—	G 1/8	G 1/8	—	21	10	57	96	14
NTK 18 AL	18	49	116	8	42	25,0	M 10	—	—	G 1/8	G 1/8	—	21	10	62	101	16
NTK 25	25	64	138	9	52	30,5	M 16	—	—	G 1/4	G 1/4	—	25	10	73	125	22
NTK 40	40	84	140	12	54	33,0	M 16	—	—	G 3/8	G 1/4	—	40	15	73	123	32
NTK 55NF	55	110	125	19	55	38,0	M 20	96	—	G 3/8	G 3/8	4x8,5	40	30	60	108	46
NTK 55HF	55	110	115	29	65	47,0	M 20	96	—	G 3/8	G 3/8	4x8,5	40	30	50	98	46
NTK 85NF	85	160	122	20	45	32,5	M 20	143	12,8	2 x G 3/8	G 3/8	6x10,5	40	20	57	105	—
NTK 85HF	85	160	112	30	55	42,5	M 20	143	12,8	2 x G 3/8	G 3/8	6x10,5	40	20	47	95	—
NTK 110	110	200	122	22	55	38,5	M 20	182	12,8	2 x G 1/2	2 x G 3/8 <sup>***</sup>	8x12,5	40	25	57	105	—

\*Central position of vibration

\*\*additional fastening possibilities on NTK 55

\*\*\*optionally M<sub>1</sub> or M<sub>2</sub>

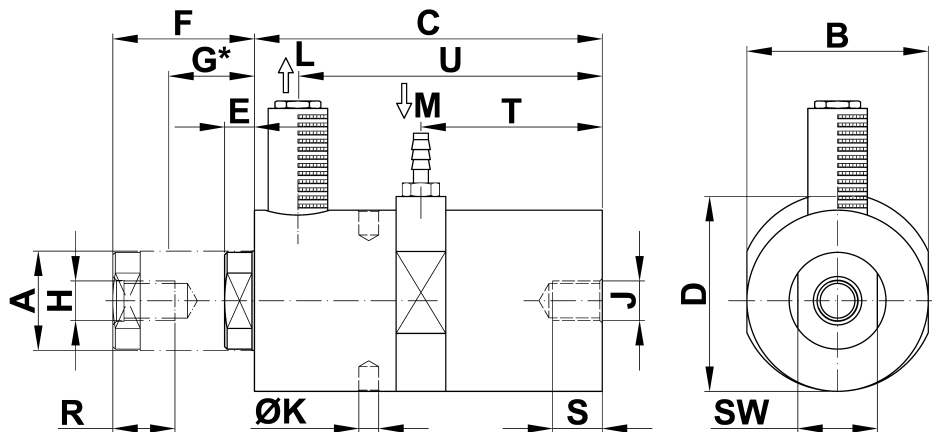

Type	A	B	C	D	E	F	G*	H	J	K	L	M	R	S	T	U	SW
NTK 8 AL	8	22	91	22	5	32	18,5	M 5	M 6	—	M 5	M 5	15	7	47,0	76,5	7
NTK 25 AL	25	50	138	54	7	52	29,5	M 16	M 16	—	G 1/4	G 1/4	25	18	72,0	120,5	22
NTK 40 AL	40	73	140	79	12	57	34,5	M 16	M 16	8	G 3/8	G 1/4	25	20	73,0	122,5	32
NTK 55 AL	55	98	133	109	20	58	38,5	M 20	M 20	10	G 3/8	G 3/8	40	35	66,0	115,0	46

\*Central position of vibration

### 3 Design and function

Vibration is generated by a freely oscillating, automatically reversing piston.

Both masses, the piston with the additional weight on the one side and the housing with the attached mass on the other side, thereby vibrate against each other in proportion to their total weights.

If a higher amplitude of the vibrating mass is required, a bigger oscillating weight simply has to be bolted to the piston.

In order to maintain the weight of the vibrating mass at a low level, it may (in case of steel housings) also be connected to the piston, allowing the housing to oscillate freely, if necessary even with an additional vibrating weight.

Chamber **A** is always filled with compressed air, while chamber **B** is alternately charged and relieved through the control bores. Since the pressurized area at **B** is twice the size of the area at **A**, the piston is pressed outwards or towards the cover.

During ventilation of **B** this process is reversed.

Since the piston is reversed before it reaches the stop, the only noise is caused by the exhaust air, which is dampened by a silencer.

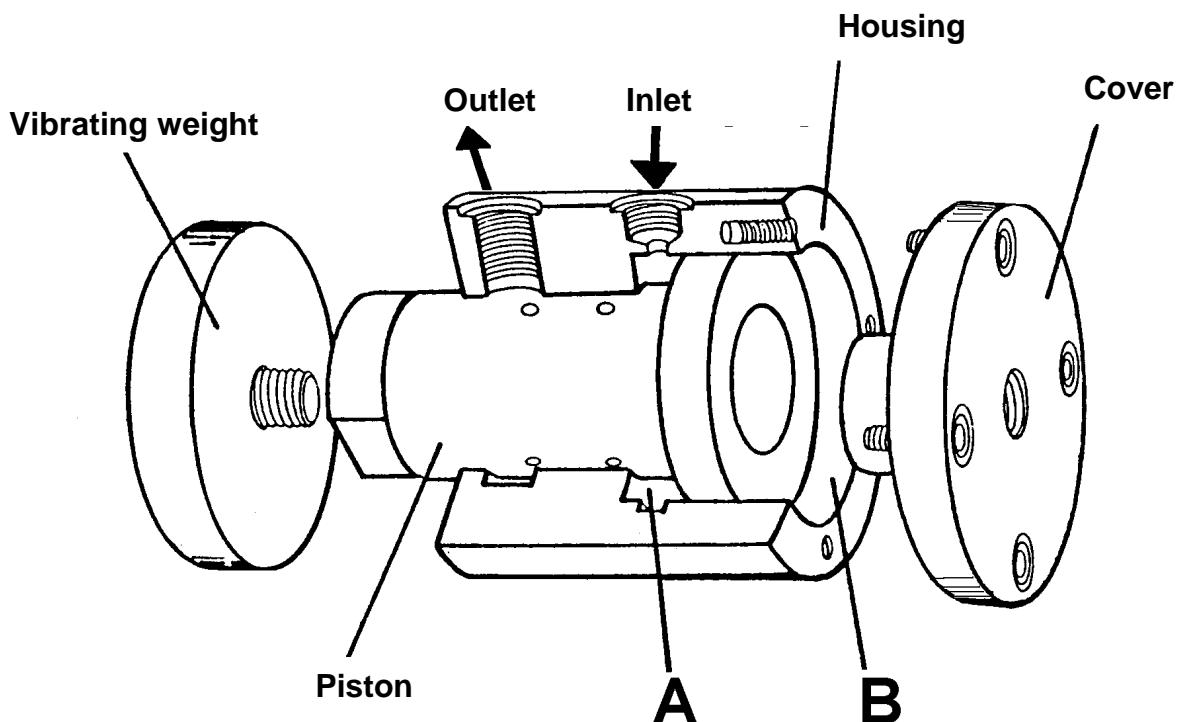

## 4 Safety



NTK vibrators work with compressed air.  
 Make sure the compressed air supply is switched off during installation.  
 Disconnect the supply lines (quick coupling) before starting other work on vibrators and supply lines.  
 Before starting operation all hoses must be tightly connected.  
 A pressurized hose coming loose can cause severe injury.

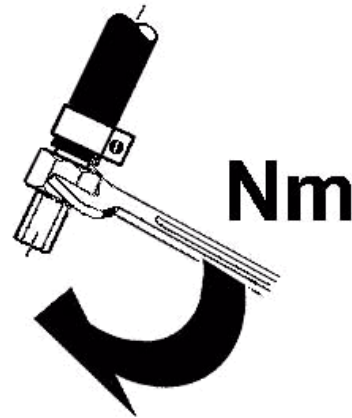

Vibrators as well as parts of the structure may come loose because of vibration. Falling parts can cause damage to persons and material.  
 Screw retention components and/or Loctite or similar must be used.  
 Screw connections must be checked and, if necessary, retightened after 1 hour of operation and then at regular intervals (normally each month).  
 In critical installation situations, the unit must be secured with a steel rope.



NTK vibrators are equipped with moving parts which can cause injury, e.g. bruises or pinching.  
 Direct touching of a vibrating part must be prevented by appropriate design measures, e.g. by screening on customer site.

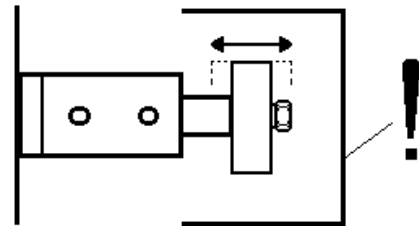

There may be a risk of getting pinched between the bolted weights and the housing of the vibrator or between the housing and the structure.  
 Bellows are available as protections. These also protect the piston rod against deposits of dust.

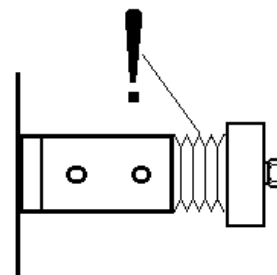

For type NTK 8 AL a cover sleeve is available.  
 This covers the piston with vibrating weight SM 8/1.

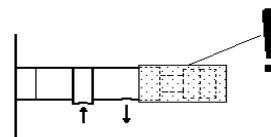

**Silencer:** Operation without silencer should be avoided in order to protect the environment against high noise values.



Technical changes to the equipment may affect the characteristics of the vibrators or even damage the units and cause the rejection of any warranty claims.

**Permissible operating conditions:**

**Operating pressure:**

2 bar to 6 bar\*

Operating pressures must not be exceeded or fallen short of.

**Temperature:**

NTK 15 x with plastic housing: 5°C to 100°C\*

NTK with aluminium housing (black): 5°C to 60°C\*

NTK with steel housing (orange): -10°C to 150°C\*

Operating temperatures must not be exceeded or fallen short of

(other temperature ranges on request)



**Lubrication:**

After receiving a written confirmation from application engineers of Netter GmbH vibrators NTK 8 AL, NTK 15 x, NTK 18 AL, NTK 25 AL, NTK 40 AL und NTK 55 AL may be operated without oil. (Exception: With dried air and under extreme ambient conditions).

When using lubricated compressed air, units with the designation „AL“ reach a considerably longer service life than comparable units made of steel or cast iron ( housings painted orange or made of stainless steel).

**All other units must only be operated with lubricated compressed air.**

When using dry air, the installation of a lubricator is mandatory.

Special versions (stainless steel, bronze) on request.

\*) Higher operating pressures and temperatures are only permitted after consultation and written confirmation by application engineers of Netter GmbH.



In dusty environments NTK vibrators must not be operated without bellows or another dust protection.

## 5 Transport and storage



Check the packing for possible shipping damage.

If the packing is damaged, check the contents for completeness and possible damage. In case of damage inform the transport agent. Compare the scope of supply with the delivery note.

The units are packed ready for installation. The type plate is mounted on the vibrator. If lubricated compressed air is required, the unit is delivered with a corresponding note next to the air inlet port. If not specified, accessories and additional components (grommet, silencer) will be supplied unmounted.

Special transport conditions are not specified.

The units should be stored in a dry and clean environment.

Units with steel housing must be oiled before being returned to the stores (put machine oil in air inlet and outlet and move the piston several times by hand in and out).

On new units the piston may be blocked by paint. In this case turn the piston slightly to loosen it.



The storage temperature may be between -40°C and +150 °C.  
(This does not apply for operating temperature, compare with **chapter 4 SAFETY, “Permissible**

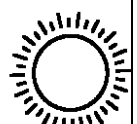

## 6 Installation



During installation please comply strictly with the safety regulations in chapter 4 and the accident prevention instructions!

Make sure the compressed air supply is switched off during installation or when working on vibrator and air supply lines.

For air connections do not use any threads longer than specified.

Parts of Teflon sealing tape must not enter into the vibrator.



### Mounting the vibrator:



Up to size NTK 40 the units can either be attached by their housing or by their piston, depending on the application.

In the case of type NTK 55 and bigger models, the housing has bores for fastening (see page 11).

If the vibrator is mounted horizontally and big vibrating weights are used (weight of freely oscillating part heavier than  $SM_{Fed.}$  - refer to the following table) the weights must be supported by a spring (drawings for this purpose are available on request).

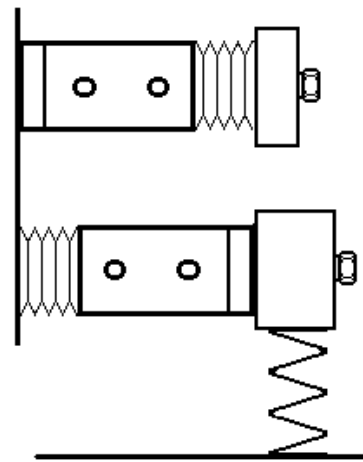

$SM_{Fed.}$  = Housing or Piston + vibration weight

Type	$SM_{Fed.}$ [kg]
NTK 8 AL	0,15
NTK 15 x	0,70
NTK 16	1,00
NTK 18 AL	0,75
NTK 25 AL	1,60
NTK 25	3,00

Type	$SM_{Fed.}$ [kg]
NTK 40 AL	3,5
NTK 40	5,0
NTK 55 AL	6,5
NTK 55 (NF)	9,5
NTK 85 (NF)	18,0
NTK 110	20,0



NTK vibrators may also be used as knockers. Consultation before use is recommended.

The piston must knock against a surface which is vertical  $\perp$  to the vibrator.

This application requires lubricated compressed air.

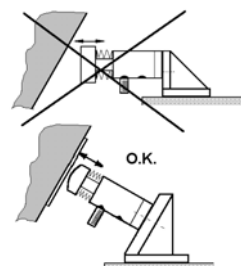



In critical installation situations the unit must be secured with clamp and steel rope.



As a protection against loosening use self-locking screws and nuts, self-locking lock washers (no spring rings) or use a liquid screw retention agent, e.g. Loctite 270.



The tightening torques can be taken from the following table. Higher tightening torques may cause fracture of screws or tearing of threads.

Inadequate screw connections may cause loosening of units by vibration. This can cause damage to persons and material!



**Recommended average tightening torques for screws property class 8.8 used on NTK-housings and pistons (screws as delivered, not additionally greased or oiled):**

Type	Thread*	Tightening torque
NTK 8 AL	M 6 (Housing)	8,5 Nm
NTK 8 AL	M 5 (Piston)	5,9 Nm
NTK 15 x	M 10	18 Nm
NTK 16	M 10	40 Nm
NTK 18 AL	M 10	40 Nm
NTK 25	M 16	95 Nm
NTK 25 AL	M 16	95 Nm
NTK 40	M 16	180 Nm
NTK 40 AL	M 16	180 Nm
NTK 55	M 20	345 Nm
NTK 55 AL	M 20	345 Nm
NTK 85	M 20	400 Nm
NTK 110	M 20	430 Nm

\*use total length of thread



For units NTK 55, NTK 85 and NTK 110 use at least 4 of the bores in the housing to mount the housing to the vibrating mass.

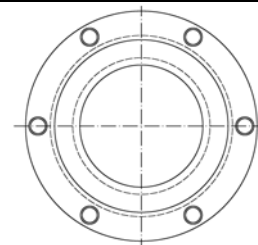

**For these screws the following tightening torques are specified:**

Type	Thread	Tightening torque [Nm]
NTK 55	M 8	25
NTK 85	M 10	51
NTK 110	M 12	87



In case of oil free operation or operation in dusty environments, NTK vibrators must not be operated without bellows or another dust protection. The permissible temperature range must not be exceeded or fallen short of during operation, see chapt. 4 **Safety – Permitted Operating Conditions**.



For the installation of the bellows the contact surfaces on vibrator and weight must be thoroughly cleaned. These surfaces must be free of oil. To install the bellows pull the contact foil (A) off on one side and stick the bellows to the vibrator (pull over the piston). Retain the piston with an open end spanner and fasten the weight with a suitable screw of quality 8.8. Lock the screw. Remove the foil on the opposite side and press the bellows against the contact surface. The bellows can be removed at any time (Velcro fastening).

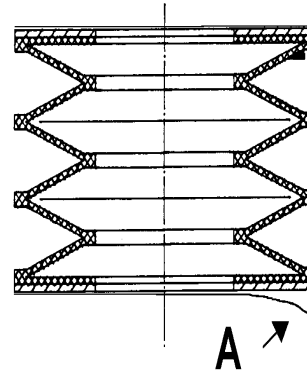

When using compressed air as drive medium, it must be clean (filtered). Unfiltered air leads to excessive wear, clogging of the silencer and complete damage of the vibrator (seizure of piston). The compressed air supply must be reliably fastened.

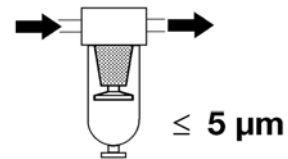

Filter recommended

**Air supply line:**

The air resistance increases with the hose length. The following recommendations refer to hose lengths of max. 3 m up to the next bigger hose cross section. For longer supply lines we recommend bigger cross sections.

**Air discharge line:**

If the exhaust air is discharged, the discharge hose must have a bigger nominal width than the air supply hose, in order to prevent throttling of the vibrator. This would otherwise reduce the amplitude.

**Minimum cross-sections for valves and hoses:**

Type	Connection threads	Hose size	3/2-way valve
NTK 8 AL	M 5	NW 4	M 5 oder G 1/8, NW 2
NTK 15 x	G 1/8	NW 4	G 1/8, NW 4
NTK 16	G 1/8	NW 6	G 1/8, NW 4
NTK 18 AL	G 1/8	NW 6	G 1/8, NW 4
NTK 25	G 1/4	NW 6	G 1/4, NW 6
NTK 25 AL	G 1/4	NW 6	G 1/4, NW 6
NTK 40	G 1/4	NW 6 - 9	G 1/4, NW 6-7
NTK 40 AL	G 1/4	NW 6 - 9	G 1/4, NW 6-7
NTK 55	G 3/8	NW 9 - 12	G 3/8-G1/2, NW 9-12
NTK 55 AL	G 3/8	NW 9 - 12	G 3/8-G1/2, NW 9-12
NTK 85	G 3/8	NW 12	G 1/2, NW 12
NTK 110	G 3/8	NW 12	G 1/2, NW 12

**Checklist for installation:**

- 1) Install the unit. Lock the fastening screws.
- 2) Assemble maintenance unit, valve, supply line, silencer.
- 3) If necessary (dust, risk of pinching) install a bellow.
- 4) If required, mount an additional weight (vibrating weight) to piston or housing - support with spring if necessary.
- 5) Have fastening screws been locked? Check!
- 6) Has the unit been secured against falling down?

**7 Start-up / Operation**

Start-up of the vibrators can be performed immediately after the correct installation.

The frequency can be adjusted or regulated with the pressure regulator on the service unit. Use a 3/2-way valve!

The amplitude can be regulated with a throttle installed in the exhaust air outlet.

**Attention:** Reduced cross-sections (observe NW) already throttle.

**Standard installation**

Special plans on request

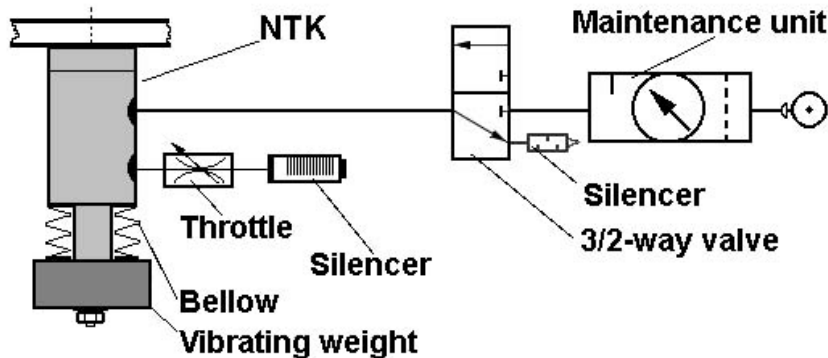

If lubricated compressed air is specified for the NTK (orange housing or stainless steel housing): Fill the oil-mist lubricator with acid-free and resin-free pneumatic oil, ISO viscosity class according to DIN 51519, VG 5 to VG 15 (only for normal temperature), fill with SAE 5 to SAE 10 for ambient temperatures above 60 °, then adjust amount of drops **while the unit is running**.

NTK 16	- 1-2 drops/min
NTK 25	- 1-2 drops/min
NTK 40	- 2-3 drops/min
NTK 55	- 2-3 drops/min
NTK 85	- 3-4 drops/min
NTK 110	- 3-4 drops/min



**ATTENTION:**  
Adjust number of drops while unit is running.  
Only after the adjustment and correct function of the mist lubricator the unit is ready for operation.



When using dried air and under extreme ambient conditions, the installation of an upstream lubricator is required.

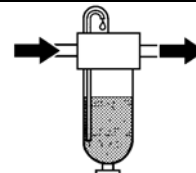

### Choosing the amplitude:

Amplitude and frequency will change in dependence on the weight attached to the piston. Lower weight or no weight mean higher frequency and smaller amplitude. Higher weight = bigger amplitude, lower frequency.

### Regulating the amplitude:

The amplitude can be regulated by throttling the exhaust air (installation of a throttle in the discharge port).

With this the centrifugal force can be reduced. The frequency remains almost unchanged.

### Regulating the frequency:

The frequency can be reduced by lowering the air pressure at the inlet port of the NTK.

This also reduces the centrifugal force. The amplitude remains almost unchanged.

### Checklist for commissioning:

- 1) Check all hose connections before opening the compressed air supply.
- 2) Adjust the desired frequency on the pressure regulator.
- 3) Adjust the desired amplitude by throttling the exhaust air.
- 4) Adjust the mist lubricator, if existing.



The fastening screws for vibrator and vibrating mass must be retightened or checked after 1 operating hour.

## 8 Service / Maintenance



When servicing the unit please observe the safety regulations in chapter 4.



### Retightening:

Screw connections must be checked and, if necessary, retightened after 1 hour of operation (after initial start-up) and then at regular intervals (normally each month). The specified torque must thereby be observed (see chapter 6).



Before each inspection and service work shut off the compressed air supply and secure it against unintended activation!



### Inspection for hidden wear:

Due to the close tolerances minor wear can lead to a reduction in performance. Pull the piston out of the unit with a jerk (if necessary remove any O-rings on the piston beforehand). Nevertheless there must be no metal end contact, as otherwise the air cushion is no longer effective (reduction in performance, start of wear).

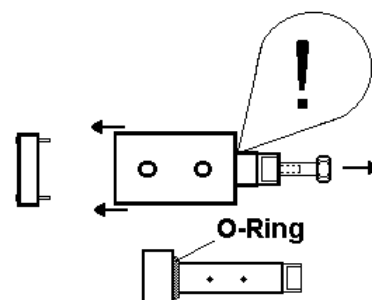

**Mist lubricator:**

With a mist lubricator connected in series make sure that it works as specified (contents diminishing? number of drops/h?). Top up oil.

**Filter:** Empty the filter when required, clean the filter insert (wash out).

**Cleaning:**

All NTK vibrators can be externally cleaned with pressure water, as long as the exhaust air is discharged through a hose or the exhaust openings are closed. Water must not enter through the silencer into the piston chamber.

**Contamination:**

Especially on units working with oil-free air contaminated air can cause a deposit of dirt or dust which slows the vibrator down.

If this is noticed (power drop or even standstill) the unit must be opened and cleaned inside. The dirt film must be cleaned off with an oiled cloth from the inside of the housing and from the piston. Further notes can be found in chapter 9 „Troubleshooting“.

The maintenance intervals mainly depend on the purity of the drive medium.

## 9 Troubleshooting

<b>Fault</b>	<b>possible cause</b>	<b>Remedy</b>
No starting	Connection mixed up.	See illustration in chapt. 3 „Design and Working Principle“, inlet on cover side, outlet on piston side.
	Air supply	Check if pressure is sufficient? Check valve. It must be a 3/2 way valve which vents the supply line to the vibrator.
	Cover loose.	A leaking cover will cause standstill. Tighten the screws.
	Line cross-sections	Observe minimum cross-sections, see specifications under „Installation“
	Line between valve and NTK too long	Causes slow starting and possible standstill of piston in central position. If necessary install a pilot-controlled 3/2-way valve in front of the vibrator
	Exhaust air excessively throttled	Open the throttle further. Clean the silencer.
	Piston slowed down in central position.	Make sure that the piston can oscillate freely. It must not be positioned in central position by external influences.
Rattling	Screws loose.	Check screws on piston and housing.
Power drop	No lubrication.	Check function of lubricator if lubricated compressed air is specified.
	Unit soiled.	Dismantle, remove dirt film.
	Wear	Check unit and piston for visible wear.
	Design	Check size of unit. Has the size been chosen correctly?
	Pressure too low.	Check the pressure at the inlet of the unit (!) during operation. If necessary, increase the pressure.

## 10 Spare Parts

Please provide the following information when ordering spare parts:

1. **Type of unit**
2. **Description of spare part**
3. **Required quantity**



Please note: Piston and housing are matched to each other and can only be delivered together.

# 11 Appendix

## 11.1 Accessories

The following accessories are available for linear vibrators of type NTK (on request):

Description	Remark
Vibrating weight SM	for all units in various sizes
Bellows NFB	for all units except NTK 8 AL - For NTK 8 AL a covering sleeve is available which can be screwed on.
Hose material and fittings	For supply and discharge of compressed air in various qualities and dimensions.
3/2-way valves	For electric, pneumatic and manual control
Throttle valves	For amplitude control, manually adjustable or pneumatically controllable (for remote control)
Maintenance units	Filter, regulator, lubricator or filter regulator (for oil-free NTK)
Time controls	Electric or pneumatic for interval operation
Brackets	For quick displacement of vibrators on containers
<b>Special designs:</b>	NTK vibrators are available for extreme temperatures, completely made of stainless steel for use in aggressive environments, for higher frequency ranges (HF-versions) as well as in shorter lengths. Information on request.

## 11.2 Disposal

Depending on the material, the parts must be disposed of according to official regulations.

### Material specifications:

All parts of these vibrators are suitable for recycling

- Black coated housing: ⇒ Aluminium
- Cover (housing NTK 15x): ⇒ Plastic (POM)
- Piston: ⇒ Stainless steel
- Screws: ⇒ Stainless steel
- Orange painted housing: ⇒ Grey cast iron
- Piston and screws for cast iron housing: ⇒ Steel

Special units (also non-lubricated units for other temperatures):

Material on request (e.g. stainless steel, bronze etc.)



All units can be disposed of through Netter GmbH.  
The current disposal prices are available on request.

## 11.3 Enclosures

### Enclosure(s):

Declaration of manufacturer



**Further information available on request:** Leaflet no. 24 (NTK), Recommendations regarding the design of small conveyor troughs with NTK vibrators and other information.